

Rectifier 230VAC-96VDC User Manual



2026.06 Version 1.2

Copyright © ePropulsion Technology Limited

THANK YOU

Thank you for purchasing a product from ePropulsion, the world leaders in clean, safe, and reliable electric marine propulsion systems and energy solutions. We are confident that you will be satisfied with your new device and welcome your feedback at www.epropulsion.com.

Conditions of Use

Before using this product, please read this user manual carefully to ensure you understand how to operate it correctly and safely. Do not use the electric energy product until you comprehend its operation. By using this product, you confirm that you have fully read, understood, and agreed to all contents of this manual. Avoid lending the product to anyone unfamiliar with its use.

ePropulsion is not liable for any economic loss or personal injury resulting from non-compliance with the instructions provided in this manual.

Please be aware that ePropulsion continually optimizes its products and reserves the right to update this manual at any time. For the latest version, visit www.epropulsion.com. If you notice any discrepancies between your product and this manual or have questions, please check the website or contact us. ePropulsion retains the final interpretation rights for this manual.

This manual is available in multiple languages; in case of discrepancies, the English version will take precedence. ePropulsion also holds all relevant intellectual property and industrial rights, including copyrights, patents, trademarks, and designs.

Safety Warning

ePropulsion prioritizes safety and aims to minimize risks to individuals and property. We recommend that anyone who comes into close contact with our products exercise caution, use common sense, follow the instructions in this manual, and pay special attention to the safety information provided both in the manual and on product labels. This includes individuals involved in the installation, operation, maintenance, and servicing of the product. The following information symbols are included in the user manual and/or on labels attached to the product:

Danger or Warning Signs:

These signs indicate potential hazards or serious risks that, if not addressed, could lead to death or severe personal injury. Please exercise extra caution and attentiveness to ensure your safety and the safety of the product.



Important warning:

Tips or important points of information that help quickly grasp the use of the energy device and enhance efficiency. Please read and follow the instructions following the safety warning signs.



Caution:

When installing, operating, maintaining or servicing ePropulsion products, there are many safety risks. It is essential to stay alert, carry out relevant tasks sensibly, and prioritize safety.



Electric shock hazard:

These areas or components may pose a risk of electric shock. The equipment uses 102.4V DC power. When accessing or opening electrical connectors, switches, cables and other electricity-related items, turn off the power to prevent electric shock.



Burn hazard:

Some parts of the outboard become very hot during operation and may remain hot even after it is turned off. Keep hands and other body parts away from these areas.



Do not connect or disconnect when the outboard is running:

These parts may pose a risk of electric shock if connected to or disconnected from the power supply during operation.

Product Serial Number

The serial number is located as shown below. Please take note of it and keep it in a safe place, as it may be required when purchasing accessories or if you need service or warranty.

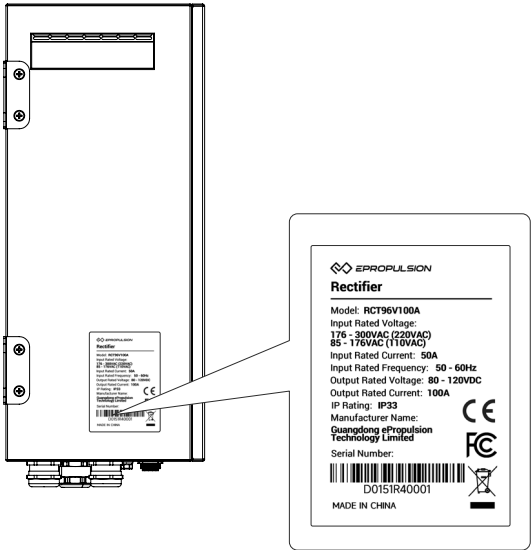

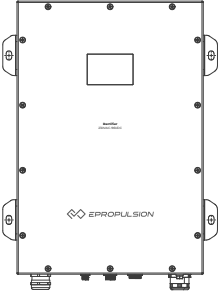
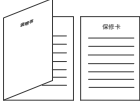

Table of Contents

THANK YOU	1
Conditions of Use	1
Safety Warning	1
Product Serial Number	3
1 Product Introduction	5
1.1 In the Package	5
1.2 Specification	6
2 Product Wiring & Installation	7
2.1 Dimensions	7
2.2 Interface Diagram & Installation Requirement	7
2.2.1 Interface Diagram	7
2.2.2 Installation Requirements	8
3 Functions	11
4 Display Operation	12
4.1 Home Page (Remote Page)	12
4.2 Local Page	13
4.3 Setting Page	14
4.4 Events Page	15
5 Limited Warranty	16
5.1 Warranty Exclusions	17
5.2 Limited Warranty Claim Procedures	18

1 Product Introduction

This rectifier is designed for 96V systems, converting alternating current (AC) to direct current (DC), with a DC output voltage of 96V. The AC input can be supplied from shore power or an AC generator, and it also functions as an On-Board Charger (OBC) to charge 96V batteries. Additionally, the rectifier has capabilities to gather power information and allows for remote control of its operations.

1.1 In the Package

Items	Qty.	Figure
Rectifier 230VAC/ 96VDC 100A	1	
Silica Gel Desiccant	1	/
User Manual	1	
Phillip Combination Screw M8x16	6	
Plain Washer M8x16x1.0	6	
Hex Nut M8	6	
Cable lug SC16-8	2	/

Items	Qty.	Figure
Cable Lug 25mm ²	4	
Cable Lug 16mm ²	4	
Heat-shrink tubing (red)	1	
Heat-shrink tubing (black)	1	

1.2 Specification

Content	Parameters
Input Voltage	176-300VAC(220VAC) 85-176VAC(110VAC)
Input Frequency	45Hz-65Hz
Output Voltage	80-140VDC(102.4VDC)
Rated Current	100A (DC output)
Adjustable Current Limit	2.5A-110A
Protection	Overload, Overvoltage, Overtemperature
Protection Rating	IP33
Certifications	CE、FCC
Dimensions	300*440*192.5mm
Weight	26.3Kg
Operating Temperature	-40°C ~ 45°C: Normal operation 45°C ~ 75°C: Derated output
Environmental Humidity	0 ~ 95%

2 Product Wiring & Installation

2.1 Dimensions

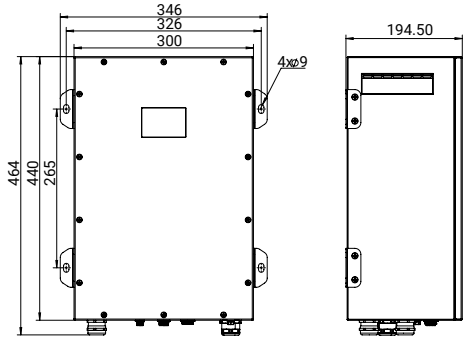

2.2 Interface Diagram & Installation Requirement

2.2.1 Interface Diagram

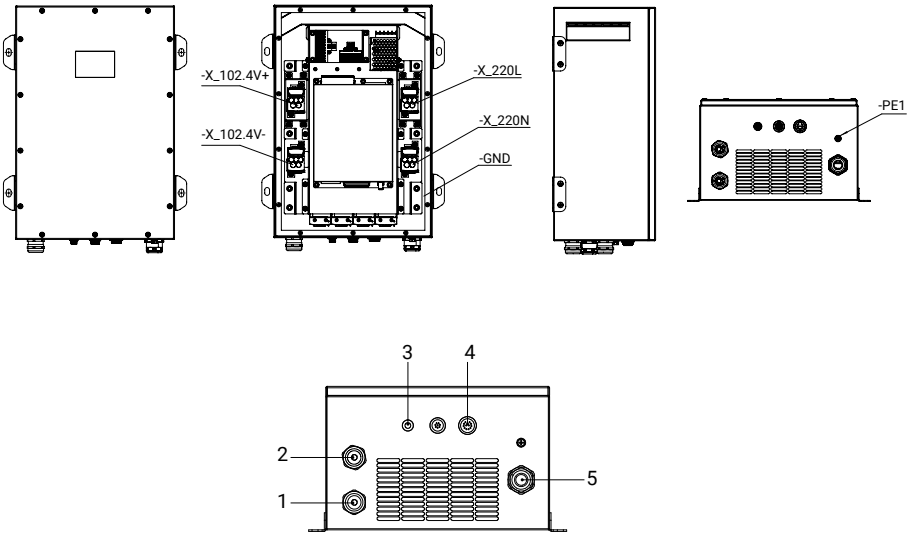

Interface	Label	Purpose	Connection Method	Pin Definition	Wire Specifications
1	DC-	Power Output	Crimping (Cable Lug or Bare Wire)	-: 102.4V-	25mm ² , Outer Diameter 13-18

Interface	Label	Purpose	Connection Method	Pin Definition	Wire Specifications
2	DC+	Power Output	Crimping (Cable Lug or Bare Wire)	+: 102.4V+	25mm ² , Outer Diameter 13-18
3	RS485	Host Controller Comm.	6Pin Connector	2: A 4: B Others: Reserved	Spirit/Navy Communication Extension Cable 5m
4	OBC	Battery Charging Comm.	12Pin Connector	1: 12V+ 2: 12V- 3: CANH 4: CANL Others: Reserved	Battery Communication Cable 1.5m or Battery Communication Cable 5m
5	AC	Power Input	Crimping (Cable Lug or Bare Wire)	L: 220VAC L N: 220VAC N PE: PE	16mm ² , Outer Diameter 15-22

2.2.2 Installation Requirements

Tools Required:

1. Phillips Screwdriver (PH2)
2. Cable Cutter: EC-50M
3. Wire Stripper: SW-1018
4. Manual Hydraulic Crimping Tool
5. Torque Wrench (13mm)
6. Wrench (M3 & M2.5)

Materials Required:

1. Rectifier (includes 4 screws, 4 plain washers, 4 hex nuts, heat-shrink tubing)
2. 2 cable lug 25mm², 2 cable lug 16mm², 1 SC16-8 terminals
3. Heat Gun

Installation Instructions



Requirements:

The product must be mounted on a vertical wall plane with sufficient structural strength to support the unit (weight: 26.3 kg). As shown in the figure below, reserve 20cm of cable bending space at the product's bottom, and ensure the space on both sides is over 10cm.



Protection Rating:

IP33. Install in a dry, clean compartment with moderate water splash risk.

Installation Steps:

1. Drill holes in the wall according to the positions and installation requirements shown in the diagram below. Reserve 20cm of cable bending space at the product's bottom, and ensure the space on both sides is over 10cm.

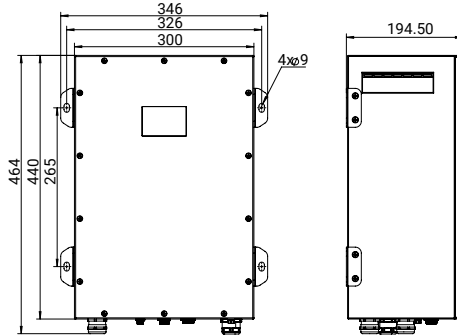

2. Remove the Rectifier 230VAC-96VDC unit, screw kit, and terminal kit from the packaging.
3. Remove the ten screws with a screwdriver and open the panel carefully, noting the internal wiring connections.
4. Unscrew the ground wire fixing nut on the panel, then disconnect the panel's grounding wire and HMI ribbon cable from the main unit.
5. Secure the device to the wall using the four provided mounting bolts.
6. Remove the three cable glands at the bottom of the unit and extract the dust plugs from the glands.
7. Feed power cables through the glands. Crimp terminals and apply heat shrink tubing. (Special attention: When wiring the 102V power cables for interfaces 1 and 2 in the previous text, approximately one-third of the copper wire used for reserving the length of the crimp terminal should be cut off, then inserted into the matching tubular terminal for crimping and tightened.)
8. Pass crimped cables through the product's ports as shown in the diagrams.

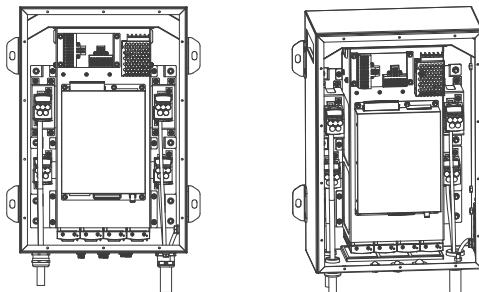

9. Insert the power cables into the terminal block according to the diagram. Secure them using a hex key and tighten the grounding cable with a No.13 wrench, referencing the torque.

Table 1: Table 1: Screw Torque Specifications

Position	Specification	Torque
Terminal	M2.5	0.36Nm
Terminal	M3	0.63Nm
Grounding Busbar	M8	18.75 Nm
Panel Fixing Screws	M4	1.5 Nm
Mounting Screws	M8	5.2 Nm

10. Reinstall the cable glands and secure the cable bundles.
11. Reconnect the grounding wire to the panel using the grounding nut and reattach the HMI ribbon cable to the main unit.
12. Install the panel onto the product front, aligning the unit's frame with the ground wire to prevent insulation damage.
13. Connect the ground wire at the bottom of the product.
14. Confirm all cable connections are secure.
15. Fasten the panel with ten screws using a Phillips screwdriver.

3 Functions

The Rectifier 230VAC/96V is a core power electronics device that converts alternating current (AC) to direct current (DC). It supports shore power or AC generators as input sources and integrates charging functionality. The unit features both manual and automatic start modes, along with an integrated display for monitoring system data. It delivers efficient and safe charging for 96V traction batteries.

4 Display Operation

4.1 Home Page (Remote Page)

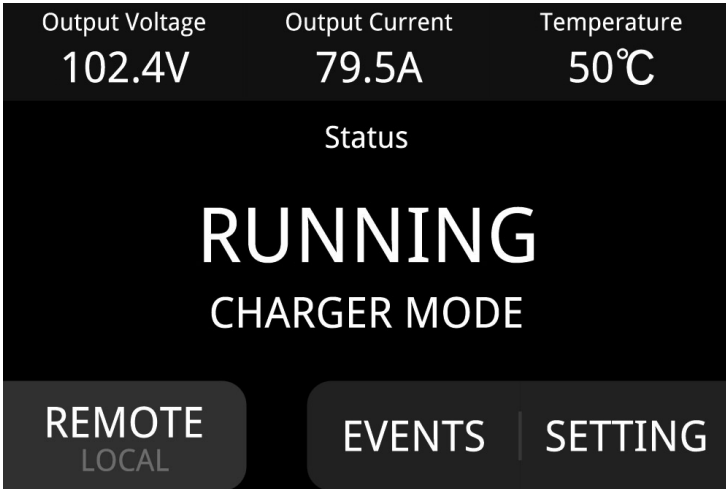

1. Parameter Display

- a. Output Voltage: 0–150.0V. Highlighted if >115V or <83V.
- b. Output Current: 0–120.0A. Highlighted if >100A.
- c. Temperature: -40°C–75°C (Environment Temperature). Highlighted if >45°C.

2. Status Indicators

Status: Run as Charger, Run as Rectifier, Stop, Error

3. Menu Options

- a. Local/Remote: Press and hold for 2.4s to toggle control modes between Local and Remote. REMOTE appears gray without active communication. Mode transitions preserve current operation until new commands are issued. Displayed parameters reflect real-time device status.
- b. Events: Tap to view fault logs. Active alarms are highlighted.
- c. Settings: Press and hold for 2.4s to access the Parameter Setting Page.

4.2 Local Page

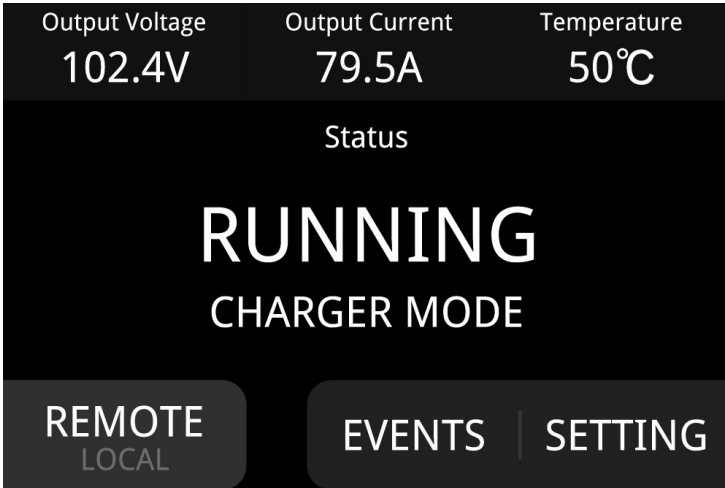

1. Status Indicators

Same as Home Page.

2. Local Control Functions

All operations on this page execute in real time.

- a. Stop: Press to stop the devices, and the output voltage drops to 0V.
- b. RUN AS Charger: Press to output a 12V wake-up signal to the battery, retrieve charging demands via CAN, and charge according to battery requirements (subject to the maximum current limit set in the Settings Page). This mode can calibrate the battery and charge to 100%, but it will disable the motor.
- c. RUN AS Rectifier: Press to activate rectifier mode with current output according to configured settings. This mode allows the rectifier to supply charge from the generator and enables the use of the motor while charging in hybrid mode.
- d. Output Setting: Press to adjust the maximum output current (minimum 2A, up to the limit set in the Settings Page). Changes take effect immediately.

3. Menu Options

Same as Home Page.

4.3 Setting Page

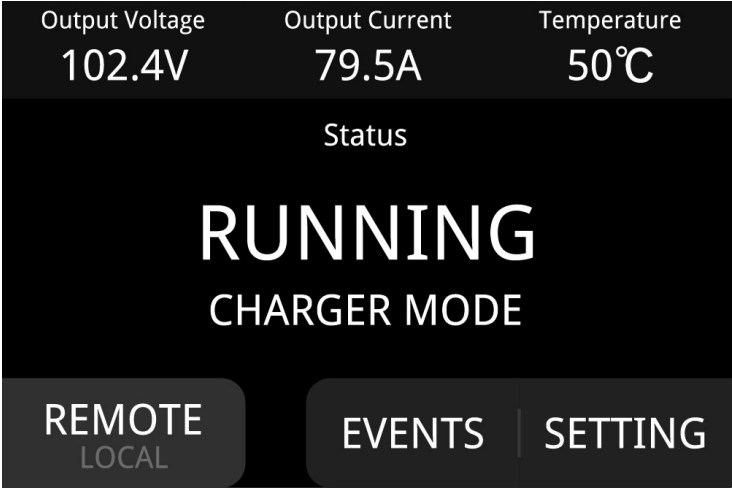

All operations on this page execute in real time.

1. Default Mode (Local control only)

Options: Rectifier, Charger, Default. Factory default: Default.

2. Output Voltage (Rectifier mode only)

The rectifier features a configurable voltage output. If connected to a battery, the voltage must not exceed the battery's limits. The actual output voltage will display the battery voltage; there will be no power output if the setting is below the battery voltage. If the set voltage is higher than the battery voltage, it will charge the battery. The factory default setting is 103.5V.

3. Max Output Current

The system should be configured based on the AC power source capacity, such as a generator or shore power. The configured value must not exceed the source's rated capacity. The factory default setting is 100A.

4. Max Loading Speed

The system should be configured based on the dynamic characteristics of the AC power source, such as a generator. The rate must not exceed the device's dynamic response capability. The factory default setting is 10A/s.

5. Menu Options

Back: Press to return to Home Page.

4.4 Events Page

DATE	TIME	ERROR	LEVEL
2024-09-01	15:30:20	Voltage Low	Shutdown
2024-09-01	15:30:10	Temperature High	Alarm
2024-09-01	15:29:00	Network Offline	Alarm
2024-09-01	12:30:20	Voltage Low	Shutdown

The screenshot shows a mobile interface for the Events Page. It features a table with four columns: DATE, TIME, ERROR, and LEVEL. The table contains four rows of error events. Below the table, there is a dark navigation bar with a 'BACK' button on the left and two arrow buttons (up and down) on the right.

1. Error Information

Same as Home Page.

- Displays date, time, error cause, and level.
- Active errors are highlighted.
- Chronological event listing.
- Error types include:

Error Message	Error	Level
SHUTDOWN_COMMON_FAULT	Others Fault	Stop
FAULT_SHUTDOWN_bit1	Rectifier Module Fault	Stop
CURRENT_CONSTANT_bit2	Over Limiting Current	Alarm
FAN_FAULT_bit3	Fan Fault	Stop
OVERVOLTAGE_INPUT_SD_bit4	Input Power Voltage High	Stop
UNDERVOLTAGE_INPUT_SD_bit5	Input Power Voltage Low	Stop
OVERVOLTAGE_OUTPUT_SD_bit6	Output Power Voltage High	Stop
UNDERVOLTAGE_OUTPUT_bit7	Output Power Voltage Low	Alarm
OVERCURRENT_SHUTDOWN_byte7bit0	Over Rated Current	Stop
OVERTEMPERATURE_SHUTDOWN_byte7bit1	Module Temperature High	Stop

2. Menu Options

Back: Press to return to Home Page.

5 Limited Warranty

Guangdong ePropulsion Technology Co., Ltd. (“ePropulsion”), China, warrants its products to be free of defects in material and workmanship under normal usage with proper installation and routine maintenance for a period of twenty-four (24) months from the date of delivery of invoice (the “Limited Warranty Period”). The Limited Warranty is provided to the first end customer of ePropulsion products ONLY. The Customer is entitled to free repair or replacement of defective or non-conforming parts. Any warranty claim must be made within six (6) months of discovery of issues as provided below.

If the Limited Warranty Period has expired, you can still enjoy maintenance services from dealers/distributors authorized by ePropulsion (the “ePropulsion Service Partners”) who will endeavour to keep costs to a minimum.

In all warranty cases, ePropulsion will only bear the repair or replacement cost for items that are covered by the Limited Warranty. Any costs not covered by the Limited Warranty – such as those related to product installation, disassembly, transportation, financing, rental, etc – shall be borne by the customer alone.

Beyond the Limited Warranty, the Customer may have statutory rights in their jurisdiction according to applicable laws. Nothing in this Limited Warranty affects such rights. The Customer may have warranty claim rights arising from the purchase contract with ePropulsion Service Partners in addition to the rights granted by this Limited Warranty.

Products used for commercial or professional purposes*, even if only temporarily, are not covered by the Limited Warranty. Instead, the statutory warranty in your jurisdiction shall apply. You are encouraged to consult with ePropulsion Service Partners for applicable warranty and advice before engaging in such use.

*** Commercial/Professional Purposes include those where the product is used with the intention of making profit, or high frequency, or very high reliability requirements, etc .**

To keep your warranty valid, please note the following:



Products without the original product label will not be covered by ePropulsion’s Limited Warranty. Keep the product label intact and record the serial number from it. Never remove the label from the product;



The Limited Warranty is not transferable and will not be reissued;



The Limited Warranty may change from time to time. Please visit our website (<http://www.epropulsion.com>) for the latest version.

Capacity guarantee for high-voltage batteries

A guarantee of the capacity of the high-voltage batteries, in addition to the standard guarantee. Depending on the long-term average temperature and the usage profile, this guarantee runs for a longer life.

Comment on average temperature:

The average temperature is calculated using the Arrhenius equation; this means that higher temperatures are given a greater weighting.

5.1 Warranty Exclusions

ePropulsion may refuse a warranty claim if:

- The product is operated in contradiction to what is written in the user manual;
- Damage is caused by accident, misuse, dropping, improper care or storage, wilful abuse, physical damage, unauthorized repair;
- Water ingress is caused by external sources such as fishing nets, submersion, etc;
- Product has been modified, altered, dismantled, or had parts/accessories attached in any way not expressly permitted or recommended by ePropulsion;
- Due to failure of, or damage caused by, any 3rd party products;
- The high-voltage batteries have been repositioned in the boat, without contacting ePropulsion service. Repositioning may result in changes to cabling, and other risks to system operation;
- The battery has been incorrectly charged, overcharged, over-discharged, or operated in temp out of scope described in the user manual;
- Consumables (such as replacement propeller, anodes, oil/fluids...etc.);
- Purchases of products from unauthorized dealers or sellers;
- Normal wear and tear and routine servicing;
- Damage caused by improper packing or handling of the product during its return. The additional damage part will be deemed out of warranty;
- Incorrect shipping of lithium batteries. These are classed as a UN9 hazardous item, and must be shipped in accordance with regulations in your jurisdiction. Non-compliance may result in warranty exclusion.

5.2 Limited Warranty Claim Procedures

The process shown below must be followed in order to make a Limited Warranty claim:

1. Contact your nearest ePropulsion Service Partner with details of the problem. They will advise if such defects are covered by the Limited Warranty or any additional rights you may have from your purchase.
2. Send the defective product to them (or the Service Partner they advise) together with Proof of 1(st)-time (first time) Purchase (e.g., receipt, invoice, etc., with information of product purchased and date of purchase), the Confirmation of Online Warranty Registration, ex-factory Serial Number, etc. Note that all labels must be kept intact. Warranty claims will only be valid only when the information above is correct, genuine, and complete.
3. Make sure the product is properly packed during delivery, the original packaging is highly recommended.
4. The ePropulsion Service Partner will examine and diagnose the defective products to check the validity of the warranty claim.
5. If your warranty claim is accepted, the Product or its defective components/parts will be either repaired or replaced free of charge. Note that any delivery cost incurred in the process shall be borne by you.
6. If your warranty claim is rejected, a repair/replacement cost and fee with round trip delivery cost will be estimated and sent to you for confirmation. ePropulsion Service Partners will only begin the work after your written confirmation that you wish to proceed with the repair/replacement and will pay for it.

ePropulsion

(*In order to validate warranty, please fill in this form first and read the Warranty Policies.)

|| OWNER INFO. ||

Owner Name			
Address			
Phone		Email	

|| DEALER INFO. ||

Store Name			
Address			
Phone		Email	

|| PRODUCT INFO. ||

Date of Purchase (mm/dd/yyyy)	
Serial No.	



Thanks for reading this user manual.

If you have any concerns or find any problems while reading, please don't hesitate to contact us. We are delighted to offer service for you.

Guangdong ePropulsion Technology Limited

Webseite: www.epropulsion.com

E-Mail: service@epropulsion.com